

Product information FMQ

Magnetic-Inductive Flow Meter FMQ

Application/Specified usage

- Magnetic-inductive flowmeter for the measurement of flow rate and volume in food applications
- Suitable for liquids, slurries and pastes with a minimum conductivity of 5 $\mu\text{S}/\text{cm}$
- Precise measurement of media containing solids (< 5 % solid particle content)
- Measurement range from 30 l/h to 640 000 l/h (8 gal/hr to 169,000 gal/hr)
- Suitable for dosing and filling applications

Hygienic design/Process connection

- Conformity with 3-A standard
- All wetted materials are FDA-conform
- Sensor made entirely of stainless steel
- Meter tube in transmitter with PFA coating
- Vacuum-tight and piggable
- Electrodes made of stainless steel 1.4404 (AISI 316L)
- Sensor available with or without process connections
- IO-Link digital communication

Special features/Advantages

- High measurement accuracy even at low flow rates
- Simple, intuitive parameterization
- Automatic empty pipe detection
- PFA lining for maximum resistance to aggressive substances such as acids and bases
- Vacuum-tight, rigid flow tube lining
- Rotatable housing with illuminated graphic display
- Operation of device via optical keys without opening the housing
- Minimal maintenance and care requirements
- IO-Link digital communication

Communication

 **IO-Link**  **4...20 mA**

FMQ flowmeter



Functional principle

The principle behind this measurement method is Faraday's law of induction. This law states that a voltage is induced in a conductor that moves in a magnetic field. In the magnetic-inductive measurement method, the flowing, conductive medium acts as the conductor. Two vertically positioned field coils generate a constant magnetic field. The voltage induced in the flowing medium is measured by two stainless steel electrodes that are arranged horizontally. The voltage is directly proportional to the flow rate and can be expressed as the flow volume using the nominal tube width. The determined measurement values are made available as a counting pulse and 4...20mA standard signal or an optional IO-Link digital communication.

Magnetic-inductive measurement

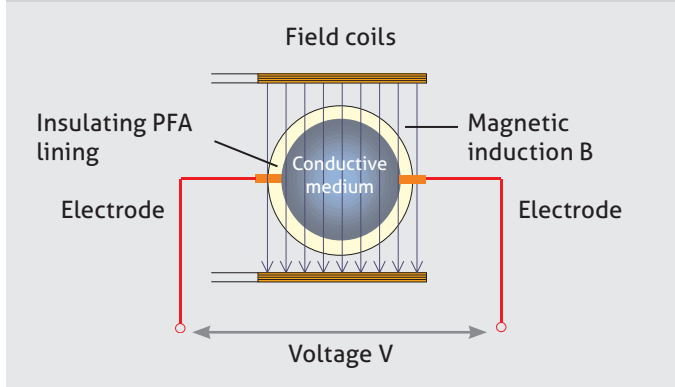

Display (optional)

- Integrated graphic display, illuminated
- Display swivels 360°
- Operation via optical keys (housing does not need to be opened)
- User guidance in English/German (switchable)

Communication

- IO-Link communication

Outputs

- 1 digital output for pulse or IO-Link communication
- 1 analog output

Supply voltage

Supply voltage
24 V DC

Measurement transmitter

- DN 10...DN 150
- PFA liner, vacuum-tight, piggable, FDA-approved
- Measurement electrodes, 1.4404 (AISI 316L)

Meter tube

Universal DIN 11864
aseptic flange

Available with butt weld,
ASME clamp or DIN clamp
process connections

Electrical connection

M12 plug

**Technical data**

Transmitter	Measuring principle Measurement ranges Nominal width	Magnetic-inductive 0.10...10 m/s DN10...DN100 (1/2"...4")
Process connection (optional)	Transmitter Tube standards	Aseptic flange DIN 11864-2, Form A Inside diameter as per DIN 11850 Series 2 Food: DIN 11850 Series 2, OD Tube (ASME BPE)
Materials	Pipe connection Seal Transmitter housing Transmitter lining Electrodes Converter housing Sight glass M12 plug	Food: 1.4404 (AISI 316L) Food: EPDM, Silicone (FDA CFR 21.177) 1.4301 (AISI 304), blasted PFA (FDA CFR 21.177) 1.4404 (AISI 316L) 1.4404 (AISI 316L) PMMA (acrylic glass) Polyamide
Temperature ranges	Ambient Process CIP / SIP cleaning	-25...+60 °C 0...+100 °C up to 130 °C max. 30 min
Operating pressure	DN10...100	0.1...17 bar (PN16)
Protection class		IP 67
Transmitter	LC display Electrical connection Supply voltage Power consumption	Graphic LCD, 46 mm x 23 mm, back-lit with auto dimming feature M12 plug (DC power supply only) DC: 24 V ±10 % Max. 2.5 W (without display) / Max. 3.0 W (with display)
Measurement accuracy		±0.5 % ±2 mm/s, under reference conditions as per DIN EN 29104 and VDI/VDE 2641
Product conductivity		> 5 µS/cm, for demineralized water > 20 µS/cm
Digital output	1 x optocoupler, passive Configurable as pulse output or IO-Link communication	24 V / 20 mA, pulse sequence max. 1 kHz IO-Link
Analog output (flow rate)	active Load resistance	(0)/4...20 mA Max. 500 Ω

FMQ Dimensions

FMQ dimensional drawing

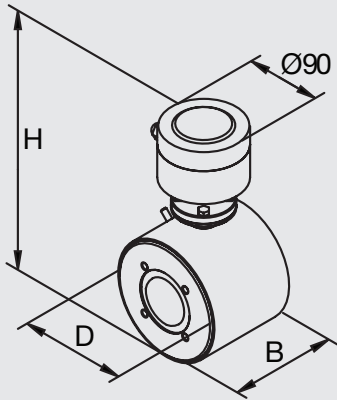

FMQ dimensions, incl. measurement range and weight

Nominal width DN	B [mm]	D [mm]	H [mm]	Measurement range [l/h]	Weight [kg]
					Transmitter and converter (display unit)
10	104	90	201	30...3.000	4
15	104	90	201	70...7.000	4
25	104	90	201	180...18.000	4
32	104	105	216	300...30.000	5
40	104	105	216	450...45.000	5
50	104	130	241	700...70.000	6
65	160	130	241	1.200...120.000	6
80	160	155	266	1.800...180.000	10
100	200	170	281	2.800...280.000	15

FMQ dimension equipped with Anderson-Negele process connection

FMQ dimensional drawing

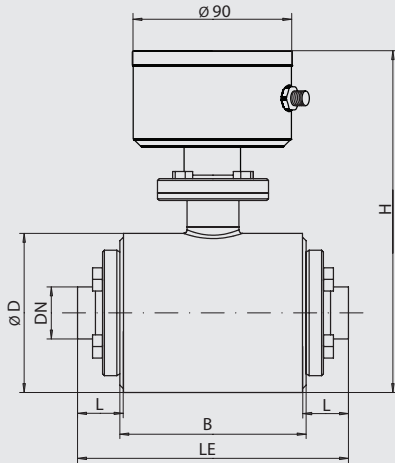

Main application area: Food | Material: 1.4404

Transmitter Ø	Pipe DN [mm]	Pipe size OD x WT [mm]	installation length LE		
			Weld flange DIN 11850 Series 2 [mm]	Tri-Clamp ASME [mm] (* Tri-Clamp size)	DIN 32676 Clamp [mm]
10	10	12.7 x 1.65	152	172 (½")*	209
15	15	19.05 x 1.65	152	203 (1")*	209
25	25	25.4 x 1.65	152	203 (1")*	223
32	32	38.1 x 1.65	152	203 (1½")*	223
40	40	38.1 x 1.65	152	203 (1½")*	223
50	50	50.8 x 1.65	152	203 (2")*	223
65	65	63.5 x 1.65	208	229 (2.5")*	303
80	80	76.2 x 1.65	212	251 (3")*	308
100	100	101.6 x 2.11	252	302 (4")*	348

Main application area: Food | Material: 1.4404 (AISI 316L)

FMQ Magnetic-Inductive Flow Meter

Nominal diameter/size

010	10 mm
015	15 mm
025	25 mm
032	32 mm
040	40 mm
050	50 mm
065	65 mm
080	80 mm
100	100 mm

Certificate

S None

Display / Cap

L Optical LED status display (not available with M12 connection options K or L)
B Blind stainless steel cap
D Graphic display

M12 Connection / Communication

O M12 connector, 4-pin, plastic
K M12 connector IO-Link, 4-pin, stainless steel
L M12 connector IO-Link with switch input, 5-pin, stainless steel
S M12 connector without switch input, 4-pin, stainless steel
M M12 connector with switch input, 5-pin, stainless steel

Connection

0 Butt-weld
1 ASME clamp
2 DIN clamp

Elastomer

A EPDM
B Silicone

FMQ 010 S L O O A

Accessories

42117H0025	5-Conductor w/25' cable
42117H0050	5-Conductor w/50' cable
42117H0100	5-Conductor w/100' cable
57001A0001	Display board kit
57002A0001	Display cap kit
57002B0001	Status Light cap kit
56623D0004	4-pin M12 connector kit

Graphic Display

